

# SALUS<sup>®</sup>

CONTROLS

Electronic Thermostat With RF  
Model No: ERT20RF



INSTRUCTION MANUAL



## PRODUCT COMPLIANCE

This product complies with the essential requirements of the following EC Directives:

- Electro-Magnetic Compatibility directive 2004/108/EC
- Low Voltage Directive 2006/95/EEC
- EC Marking directive 93/68/EEC

## SAFETY INFORMATION

These instructions are applicable to the SALUS Controls model stated on the front cover of this manual only, and must not be used with any other make or model.

This accessory must be fitted by a Competent person, and installation must comply with the guidance provided in the current editions of BS7671 (IEE Wiring Regulations) and Part 'P' of the Building Regulations. Failure to comply with the requirements of these publications could lead to prosecution.



**Always isolate the AC Mains supply before opening or removing the unit from the wall or wall box.**

**When fitting batteries don't mix old and new batteries together.  
Do not use rechargeable batteries.**

**When fitting batteries don't mix old and new batteries together.  
Do not use rechargeable batteries.**

Please leave these instructions with the end user where they should be kept in a safe place for future reference.

## INTRODUCTION

The ERT20RF from SALUS Controls is a stylish and accurate dial thermostat. This thermostat has been specifically designed to be used for both Volt Free and AC heating applications, can replace most common residential thermostats and is designed to be used with electric, gas or oil heating control systems. Unlike ordinary single unit design thermostats, this is a new type of thermostat separating the operational functions into two units.

The receiver is used for wiring connections and on/off control.

The thermostat provides the user interface and temperature sensing / control. The two units are linked together by a Radio Frequency (RF) signal.

### General Features

- Volt free switching option
- User friendly dial
- Simple to use
- 16 Amp receiver
- LED Indication

## INSTALLATION

Please read the important safety information at the start of this manual before you begin to install the device.

### Thermostat

The ERT20RF Thermostat is easily installed using the back plate supplied with the unit – this is used purely for mounting purposes, as no wiring is needed for the thermostat. The back plate can be mounted directly to the wall surface.

The ideal position to locate the ERT20RF Thermostat is about 1.5m above floor level. It should be mounted in a location where the thermostat is accessible, reasonably lit and free from extremes of temperature and draughts. Do not mount the thermostat on an outside wall, above a radiator or in a location where it may be subjected to direct sunlight.

To ensure trouble free operation of the Radio Frequency (RF) signal, always ensure that the thermostat is mounted away from any possible sources of interference (such as radios, TV sets, computers, etc.), and is not mounted on or in close proximity to large metal objects. Installing the ERT20RF in enclosed areas such as cellars and basements is not recommended.



1. Mount backplate on wall and ensure correct orientation.



2. Insert the 2 x AA batteries (supplied). If you are installing for the first time please put the thermostat to one side and proceed to page 6.



3. After RF pairing is complete on page 7 then slide the thermostat onto the backplate ensuring both sides are engaged. You will feel a positive click when located properly.



For replacing the batteries reverse the process in step 3.

When the batteries need replaced the LED below the dial will flash

## Receiver



**NOTE:** All electrical installation work should be carried out by a suitably qualified Electrician or other competent person.

If you are not sure how to install this digital thermostat consult either with a qualified electrician, heating engineer or your boiler / heating system supplier for advice on how to continue.

The ERT20RF Receiver should be mounted in a suitable location that is both accessible for the connection of mains and control wiring, and allows good reception of the RF signal. The Receiver needs a 230V AC mains supply to operate, and this should be fused appropriately (13A max.). The Receiver should be mounted in a location where it will not come into contact with water, moisture or condensation.

The Receiver ON/OFF switch is accessible from the front face of the receiver, as shown in this picture:

On the front cover of the receiver you will see that there is the ON/OFF switch and two LEDs. The bottom LED (RED) will illuminate when the switch is in the 'ON' position and the unit is receiving power. The top LED (GREEN) illuminates when the receiver unit is receiving a heat call transmission from the thermostat.



The wiring terminals are located on the rear of the receiver, as shown in this picture:



## RECEIVER WIRING TERMINALS

Terminal	Identifier	Description
1	NO	Normally Open [N/O]
2	COM	Linked Live feed (230V AC heating applications only)
3	L	Live feed (230V AC)
4	N	Neutral

## TYPICAL WIRING INSTALLATIONS

### a. Volt Free Installation

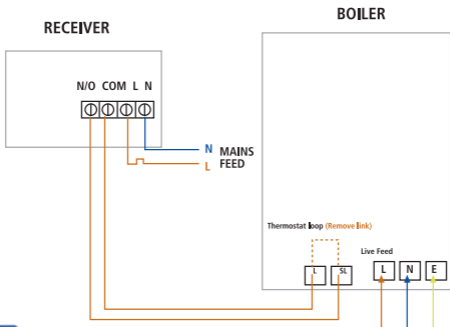

#### Notes:

- Receiver unit should have a permanent 230V AC main supply
- Confirm that the Boiler has an external thermostat loop and is configured for Volt Free switching

## b. 230V Installation

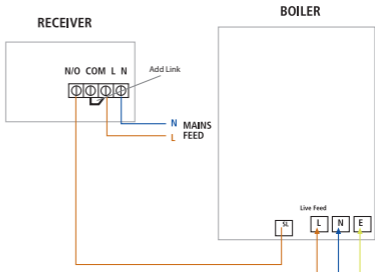

### Notes:

- Receiver unit should have a permanent 230V AC main supply
- Confirm that the Boiler is configured for 230V switching

**PLEASE DO NOT SWITCH THE RECEIVER ON UNTIL YOU ARE READY TO PAIR WITH THERMOSTAT**

## RF PAIRING

Switch on receiver and the RED LED should start flashing. If receiver was already switched on, switch OFF then back ON again the RED LED should start flashing.

Now press and hold the SYNC button on the rear of the thermostat for 3 seconds. The LED below the dial will start flashing.

Now check the LED on the receiver, once RF pairing is successful the LED on the receiver will stop flashing

Now press and hold the SYNC button on the thermostat for 3 seconds. The thermostat should now be paired with the receiver.

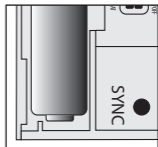

*Back of unit*



## TESTING THE RF TRANSMISSION

It is important to site both the receiver and thermostat in locations where the RF signal cannot be interrupted.

The receiving range between thermostat and receiver is approximately 30 metres indoors, however many factors can affect the RF transmission and shorten the operating distance, e.g. shielding by thick walls, foil back plasterboard, metal objects such as filing cabinets, general RF interference, and so on.

The range is generally large enough for most household applications, to check the RF reception, follow the following steps:

1. Turn the thermostat to 30°C. The LED under the dial should come on.
2. Check the Green LED on the receiver unit - it should be lit and boiler should fire.
3. Turn dial down to 5°C. The LED under the dial should go off.
4. Wait for a few seconds and the Green LED should switch off. The boiler should also switch off.
5. If the operation of 1-4 is successful then you have a good RF link between the thermostat and the receiver.
6. Return the dial to the preferred set temperature for the application.

If you are unable to get a stable RF connection between the receiver and thermostat, check that the receiver is both switched on and has a mains supply (red LED illuminated). If this isn't a problem then try pairing the thermostat to the receiver again. See page 8.

## CONFIGURATION

Your ERT20 thermostat is configured for HEATING control and simple ON/OFF switching, however it can be configured for COOLING. This is easily done by changing the “jumper” setting. The “JUMPER” peg is located on the rear of the ERT20TX.

### JUMPER Position

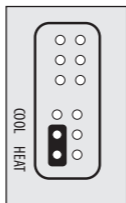
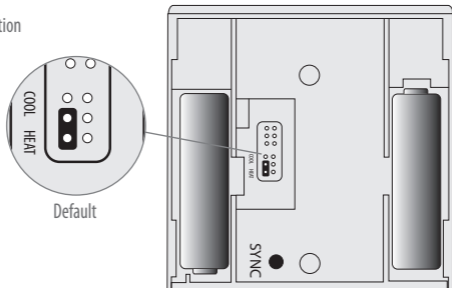

Default HEAT

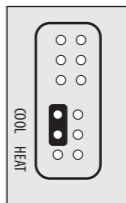

COOL

## SETTING ROOM TEMPERATURE

The temperature can be changed by rotating the dial. The position of the dial allows the user a clear indication of the required room temperature, and the status of the heating system.



Temp set for 15°C

When the ERT20RF is demanding heat. The red led below the dial will glow. When the correct temperature has been reached then the LED will go out.



If LED is flashing continuously in normal operation then the batteries need replacing.



## FROST PROTECTION

Set the dial to 5°C this will provide protection from freezing temperature.



Temp set for 5°C



## MAINTENANCE

The ERT20RF electronic thermostat requires no special maintenance. Periodically, the outer casing can be wiped clean using a dry cloth (please DO NOT use solvents, polishes, detergents or abrasive cleaners, as these can damage the thermostat).

There are no user serviceable parts within the unit.

Should the ERT20RF electronic thermostat fail to function correctly, check:

- The batteries are the correct type, fitted correctly and are not exhausted - fit new batteries if in doubt. LED will flash continuously when battery power is low.
- Heating or Cooling system is switched on.
- The ERT20RF receiver is switched on. Note in the event of the receiver being switched off or a power cut the receiver LED will flash for 10 minutes. The LED will eventually stop flashing and return to normal. Check jumper on the rear are set to your required application.

## WARRANTY

SALUS Controls warrants that this product will be free from any defect in materials or workmanship, and shall perform in accordance with its specification, for a period of two years from the date of purchase. SALUS Controls sole liability for breach of this warranty will be (at its option) to repair or replace the defective product.

## PRODUCT SPECIFICATION

### General

Model:	ERT20RF
Type:	Electronic thermostat, designed for Volt Free and AC heating applications.
Frequency	868 MHz

### Thermostat

Temperature Scale:	Celsius
Range:	5 °C to 30 °C
Resolution:	0.5 °C
Tolerance:	Less than $\pm 0.5$ °C at 25°C
Frost protection setpoint:	5 °C

Power Source:	2 x AA alkaline batteries (don't use rechargeable batteries)
---------------	---

### Receiver

Power Source:	230V AC / 50Hz
Switch Rating	
Switching Voltage:	0 - 230V AC / 50Hz
Switching Current:	16A resistive, 5A inductive
Protection Rating:	IP30

### Environment

Operating Temperature:	0 °C to + 40 °C
Storage Temperature:	- 20 °C to + 60 °C

For more products in the  
**SALUS** range visit...



[www.salus-tech.com](http://www.salus-tech.com)



## WARRANTY

SALUS Controls warrants that this product will be free from any defect in materials or workmanship, and shall perform in accordance with its specification, for a period of two years from the date of purchase. SALUS Controls sole liability for breach of this warranty will be (at its option) to repair or replace the defective product.

Customer Name: .....

Customer Address: .....

..... Post Code: .....

Tel No: ..... Email: .....

Engineers Company: .....

Tel No: ..... Email: .....

Installation Date: .....

Engineers Name: .....

Engineers Signature: .....

## **SALUS Controls plc**

SALUS House

Dodworth Business Park South,

Whinby Road,

Dodworth, Barnsley S75 3SP

UK.

**SALES:** T: +44 (0) 1226 323961  
E: sales@salus-tech.com

**TECHNICAL:** T: +44 (0) 1226 323961  
E: tech@salus-tech.com

# www.salus-controls.com



SALUS Controls is a member of the Computime Group

Maintaining a policy of continued product development SALUS Controls plc reserve the right to change specification, design and materials of products listed in this brochure without prior notice.

**Issue Date: Feb 2014**

00089 Ver009

